

A MODEL FOR FLUCTUATIONS OF THE SPATIAL MEAN IN A TURBULENT CHANNEL FLOW

Paolo Luchini
 DIIN, Università di Salerno, Italy

Maurizio Quadrio
 Department of Aerospace Sciences and Technologies, Politecnico di Milano, Italy

Many authors in the past decades have studied turbulent skin-friction drag reduction via Direct Numerical Simulations of a plane channel flow. When the drag reduction device is switched on at the beginning of the simulation, a (temporal) transient takes place, where the flow adapts to its new drag-reduced state; this transient is important in the numerical experiment, and needs to be carefully discarded to obtain reliable mean values. Depending on whether the comparison between the reference flow and the drag-reduced flow takes place at the same mean pressure gradient (Constant Pressure Gradient, CPG), or at the same flow rate (Constant Flow Rate, CFR), the initial transient differs. In the CPG case it involves a short-term drop in the wall shear stress τ , which allows the flow rate U to increase until it levels off, with τ recovering the nominal value. In the CFR case, τ decreases, often non-monotonically, and eventually levels out. Figure

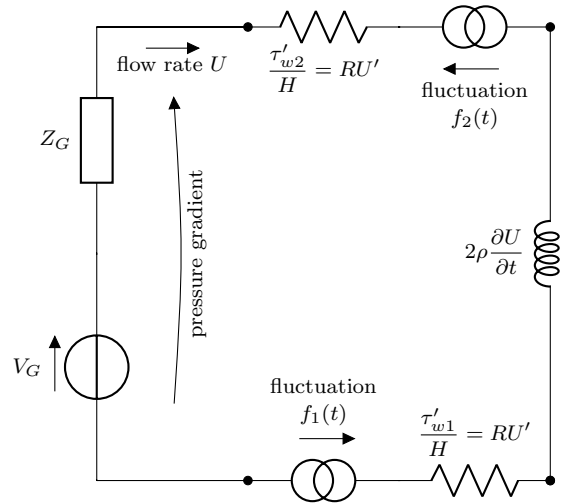

Figure 2: Circuit representation of the equation for spatial mean fluctuations.

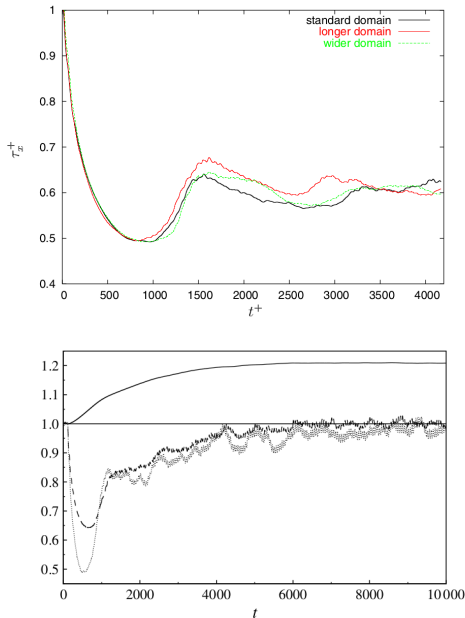

Figure 1: Initial transient occurring when spanwise oscillations of the wall are applied in a turbulent channel flow. top: transient of τ during a CFR simulation, from [2]. Bottom: transient of τ (dashed line) and U (continuous line) during a CPG simulation, from [3].

1 (top) is a plot taken from [2] for the CFR transient when spanwise-oscillations of the wall are applied to a plane channel at $Re_\tau = 200$, and shows that this transient is independent from the domain size. Figure 1 (bottom) is the corresponding CPG transient, taken from [3].

In this work, we explore the nature of such transients, and in general the relation between U and τ , by drawing an electrical analogue of the channel flow system. We also compare this model to actual data taken from an existing channel flow DNS database [1]. Among other quantities, the dataset contains the temporal history of the spatially-averaged friction at the two channel walls, the flow rate and the pressure gradient. Three equivalent simulations are available, carried out at a nominal value of the friction-based Reynolds number of $Re_\tau = 200$. The three cases, where no flow control is applied, differ in the way the forcing term in the momentum equation is specified: CFR, CPG, and Constant Power Input (CPI). The datasets are quite long, and contain the time history of wall shear, flow rate and pressure gradient, sampled every 0.2 viscous time units, and for a duration of 150,000 viscous time units. Hence each dataset contains 750,000 samples.

The equation for the (0,0) Fourier mode in a doubly periodic numerical computation is represented as the equivalent electrical circuit in Figure 2. Here the inertia of the fluid

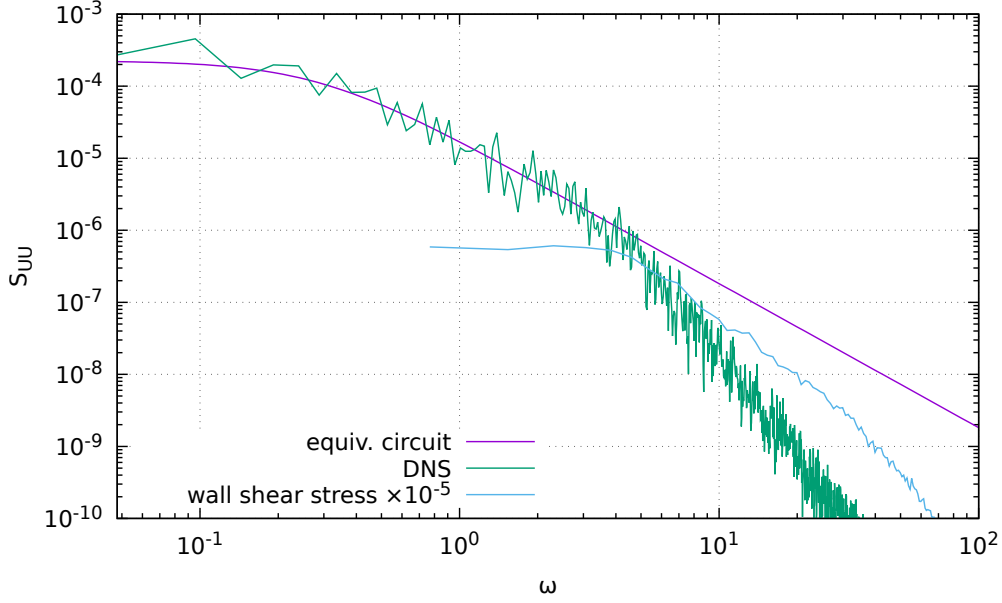

Figure 3: Spectrum of the temporal velocity fluctuations in the CPG case compared with the spectrum predicted by the equivalent circuit of Figure 2.

appears as an inductor, the externally imposed boundary condition (a linear combination of pressure gradient and flow rate, so as to encompass all possible cases) become a voltage generator with its internal impedance Z_G , and finally the shear stress at each wall is schematized as a noisy resistor, combining the static resistance (derivative of the friction factor) that the wall would oppose to a steady perturbation of the mean flow plus a voltage source of random fluctuations. The approximation only relies in this last term, and consists of considering these fluctuations as uncorrelated with the fluctuations of the mean flow, which could be reasonable for small enough frequencies.

The typical time constant of the τ_w correlation shear stress fluctuation can be assumed to be of the order of H/u_τ , based on a typical velocity u_τ and size H of the largest vortices. Correspondingly its angular frequency (ω) range can be assumed to be of the order of $2\pi u_\tau/H$, an assumption which is a posteriori confirmed by the spectra to be shown below. The static resistance (derivative of Prandtl's law) is also easily estimated:

$$H^{-1} \frac{d\tau_w'}{dU'} = \frac{2\bar{\tau}_w}{H\bar{U}} \left(1 + \kappa^{-1} \sqrt{c_f/2}\right)^{-1} \simeq \frac{1.75\bar{\tau}_w}{H\bar{U}}.$$

The circuit in Figure 2 is a classical first-order low-pass filter with time constant

$$L/R = \frac{\rho U H}{2\tau_w} = \frac{1}{2} \frac{U}{u_\tau} \frac{H}{u_\tau}.$$

The key observation here is that the time constant of the RL filter is $2u_\tau/U$ times smaller than the characteristic time of the shear-stress fluctuations. This at the same time justifies the assumption of uncorrelation, and qualitatively explains why long transients are possible.

As a test, Figure 3 displays the low-frequency end of the spectrum of CPG velocity fluctuations (which would not exist in the CFR case), compared with the spectrum produced by the equivalent circuit 2 when forced by white noise. As can be seen, a good agreement is observed up to a frequency of the order of $2\pi/H$, which not by accident is the same frequency up to which the spectrum of the wall shear stress, superimposed onto the same figure, is approximately flat. This confirms our

assumptions and shows that slow transients in the response to external perturbations can indeed be explained by this electrical analogy.

REFERENCES

- [1] M. Quadrio, B. Frohnapfel, and Y. Hasegawa. Does the choice of the forcing term affect flow statistics in DNS of turbulent channel flow? *Eur. J. Mech. B / Fluids*, 55:286–293, 2016.
- [2] M. Quadrio and P. Ricco. Initial response of a turbulent channel flow to spanwise oscillation of the walls. *J. Turbul.*, 4(7), 2003.
- [3] P. Ricco, C. Ottonelli, Y. Hasegawa, and M. Quadrio. Changes in turbulent dissipation in a channel flow with oscillating walls. *J. Fluid Mech.*, 700:77–104, 2012.